

Handheld Acoustic Camera



HA3

Hertzinno third-generation acoustic camera, HA3 series integrates a cutting-edge 144-channel MEMS microphone array with multi-mode positioning and upgraded AI algorithms, delivering a lighter, faster, and smarter solution for partial discharge detection, gas leakage detection and mechanical fault diagnosis.

Designed for precision and efficiency, the camera empowers industrial professionals to capture and quantify complex acoustic sources in real-world scenarios.

Optimized 144-channel circular array design paired with beamforming algorithms achieves $\pm 1^\circ$ localization accuracy ($\leq 1\text{cm}$ error @1m distance, 40kHz), enabling clear differentiation of dense acoustic sources.

The camera supports real-time monitoring of audio signals via Bluetooth connection to headphones. It also supports the online display of frequency spectrum diagrams.

The camera supports one-click analysis and one-click forwarding functions on the device. After taking a photo, users can analyze the file using the one-click analysis function on the device. It also supports the real-time generation of analysis reports. After completing the report analysis, users can export the file via Wi-Fi, Bluetooth or a USB interface. And the camera supports offline analysis on a PC and online analysis in the cloud.

The camera supports file management and file notes, allowing users to add notes to their photos in a variety of ways, including text, voice, photos, and tags.

hertzinno.com

Key Feature

- **144 Low-noise MEMS Microphones**
- **Partial discharge detection**
- **Gas leakage detection**
- **Mechanical fault detection**
- **Partial discharge type intelligent analysis**
- **Multiple sound sources detection**
- **Real-time sound source localization**
- **Laser rangefinder**

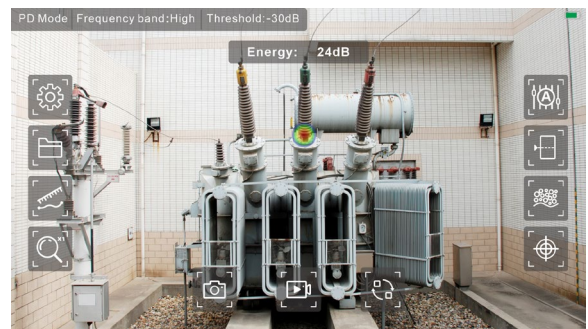

■ Specification

Model	HA3
Microphones	144 Digital MEMS microphones
Dynamic Range of Camera	-30dB ~ 120dB
Minimum Imaging Sensitivity	10kHz: 3dB SPL 20kHz: -15dB SPL 40kHz: -5dB SPL 60kHz: 10dB SPL 80kHz: 35dB SPL 100kHz: 45dB SPL
Operating Distance	0.3m ~ 200m
Dynamic Range of multiple targets	0 ~ 18dB
Frequency Bandwidth	2kHz ~ 130kHz
Space resolution	≤1cm@1m, 40kHz
General	
Optical Camera	13MP
Camera FOV	72°±3°
Lighting	LED lighting
Photo Image Resolution	4K (3840×2160), 1080P
Digital Zoom	1/2/4/8
Video Image Resolution	1920×1080@30fps, 1920×1080P@60fps
Storage	128GB
Annotation	Text, voice, photo, tags
Display	1280P×720P, 5-inch, Touch Screen
Wi-Fi & Bluetooth	IEEE 802.11a/b/g/n/ac 2.4G&5G & BT4.2
Positioning	BD, GPS, GLONASS, GALILEO
E-compass	Support
Laser Distance Measurement	0.1 - 20m(±1mm) (Laser Class II, 620 -690nm, < 1mw)
Data Transmission	USB, Wi-Fi, Bluetooth
USB Port	TYPE-C
Battery	Li-Ion rechargeable battery *2
Charging Time	2.5 h(from 10% to 90%) & PD Fast Charging
Protection Level	IP54
Tripod Mount	UNC 1/4-20
Weight	Less than 1kg
Dimension	333mm*152mm*115mm
Working Temperature Range	-20°C ~ 55°C
Storage Temperature Range	-40°C ~ 85°C
Humidity	10% -95% (non-condensing)
Applications	
Work mode	Partial Discharge Detection, Leaks Detection, Mechanical Noise Detection
Analysis Software	On-device Analysis, PC software, Cloud software

■ Dimension

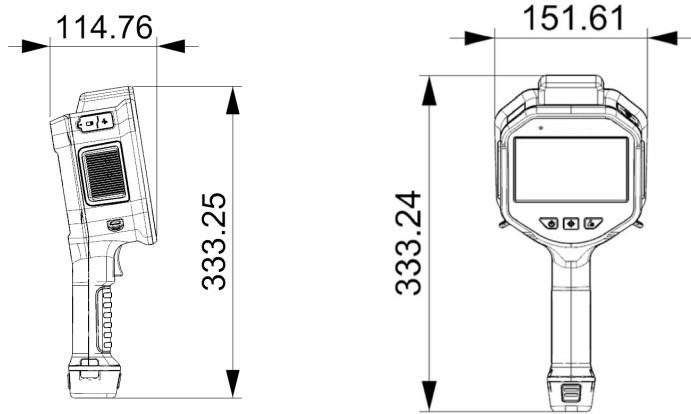

■ Packaging list

1. Acoustic Camera
2. USB Charger & Cable
3. Charging dock
4. Spare battery *1
5. Carrying case
6. User manual
7. Factory test report
8. Accessory kit

■ Safety Notice & Disclaimer

Laser Safety Warning

When operating the laser rangefinder, **NEVER aim the laser beam at human eyes or reflective surfaces.**

LED Light Warning

Avoid **prolonged direct viewing of LED light sources** (may cause temporary visual discomfort)

HERTZINNO shall not be held liable for any equipment damage or personal injury resulting from **non-compliant operation** (including but not limited to failure to read manuals, laser misuse, etc.).

Users assume all risks and legal consequences arising from failure to follow safety instructions.

■ Notes

Please note that parameters are subject to change, and we encourage you to refer to Hertzinnno's official announcements for the most up-to-date information.

Hertzinnno reserves the right to provide final explanations for any changes that may occur.

Hertzinnno offers a 2-year warranty.

